

## ECOFLOW POWEROCEAN SINGLE-PHASE

### Home Solar Battery Solution

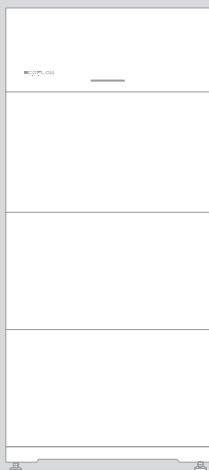

For the latest documents, please scan the QR code or visit:

Q <https://enterprise.ecoflow.com/eu/documentation>





#### **IMPORTANT**

- Before installing, operating, and maintaining the equipment, read and follow up Installation Guide and Safety Instructions.

# CONTENTS

- 1 **Safety Instructions**
- 2 **Preparing Tools and Instruments**
- 3 **What's In The Box**
- 4 **System Installation**
  - 4 Installation Environment Requirements
  - 4 Installation Space Requirements
  - 5 Installing Battery
  - 7 Installing Inverter
- 8 **Electrical Connection**
  - 8 System Overview
  - 9 System Wiring Diagram
  - 10 Connecting PE Cables
  - 10 Connecting GRID Cables
  - 11 Connecting BACKUP Cables
  - 12 Installing COM Connector With Shorting Wire
  - 13 (Optional) Installing Emergency Stop (EPO)
  - 14 Connecting PV Input Cables
  - 16 Connecting Smart Meter
  - 18 Connecting to Internet
  - 19 Installing trim cover
  - 19 Installing EcoFlow IOT Dongle ESS
  - 19 (Optional) Installing EcoFlow 4G Dongle ESS(EU)
- 20 **System Commissioning**
  - 20 Checking before Power-On
  - 20 System Power-On
  - 20 System Power-Off
  - 20 LED Indicators
  - 21 System Commissioning
  - 26 How Users Add Devices

Safety  
**Instructions**





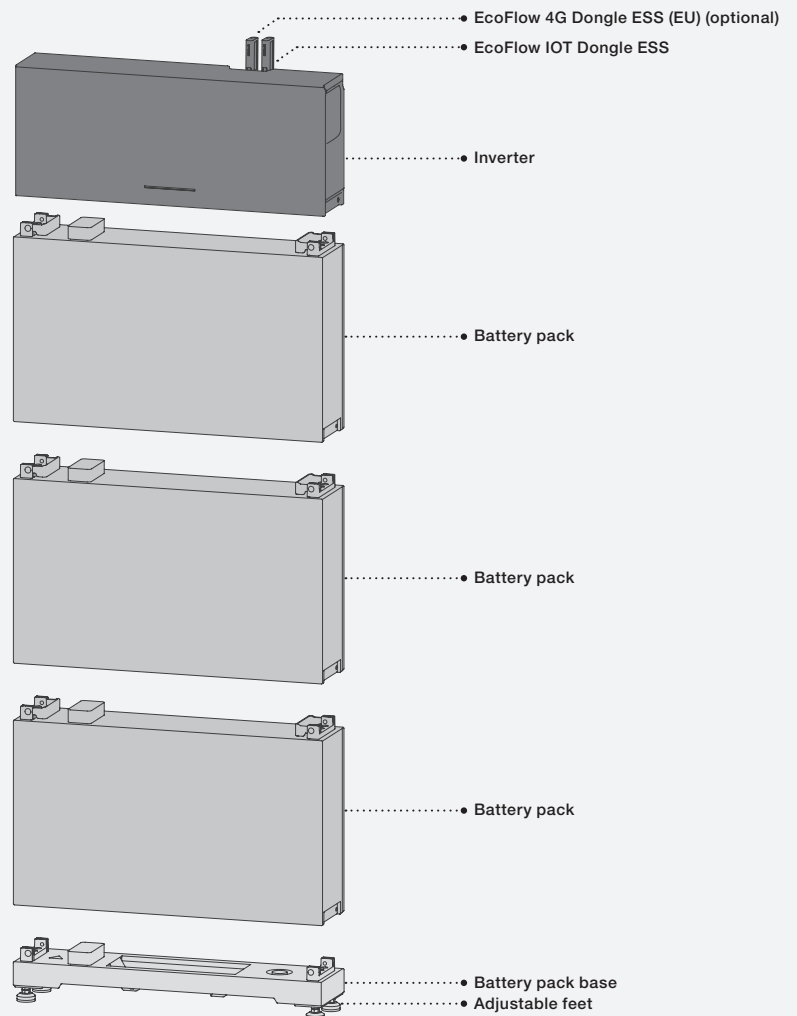





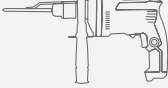

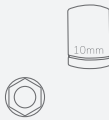

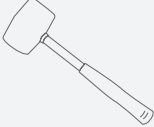

Symbol	Description
 <b>DANGER</b>	Indicates a hazard with a high level of risk which, if not avoided, will result in death or serious injury.
 <b>CAUTION</b>	Caution, risk of electric shock.
 <b>WARNING</b>	Indicates a hazard with a medium level of risk which, if not avoided, could result in death or serious injury.
 <b>CAUTION</b>	Indicates a hazard with a low level of risk which, if not avoided, could result in minor or moderate injury.
 <b>NOTICE</b>	Indicates a potentially hazardous situation which, if not avoided, could result in equipment damage, data loss, performance deterioration, or unanticipated results. <b>NOTICE</b> is used to address practices not related to personal injury.

-  **DANGER**
  - Before installing, operating, and maintaining the equipment, read and follow up Installation Guide and Safety Instructions.
  - Personnel who plan to install or maintain EcoFlow equipment must receive thorough training, understand all necessary safety precautions, and be able to correctly perform all operations.
  - Personnel who will install, operate, and maintain the equipment, including operators, trained personnel, and professionals, should possess the local national required qualifications in special operations such as high-voltage operations, working at heights, and operations of special equipment.
  - Before connecting cables, ensure that the equipment is intact. Otherwise, electric shocks or fire may occur.
  - Before installing, operating, and maintaining the equipment, **always disconnect it from all power.**
  - Wear proper PPE (Personal protective equipment) before any operations.



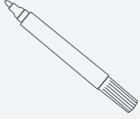
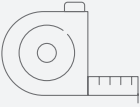

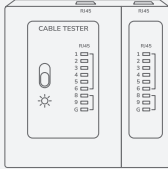

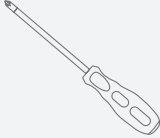
# Preparing Tools and Instruments

## • ESSENTIAL TOOLS

					
Hammer drill (with a drill bit of 8mm)	Electrical Screwdriver	Torque socket of 10mm	Multimeter (DC voltage measurement range $\geq 1000$ V DC)	Mallet	Screwdriver (PH3)
					
Cable cutter	Crimping tool	Wire strippers	RJ45 Crimping tool	Crimping tool (for tubular terminal)	Wrench (14mm)
					
Marker	Steel measuring tape	Cable tie	Network cable tester	Heat gun	Heat-shrink tubing
					
Screwdriver (PH2)					

## • OPTIONAL TOOLS









				
Vacuum cleaner	Safety goggles	Safety shoes	Safety gloves	Dust mask

# What's In The Box

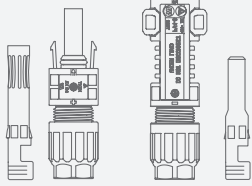
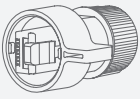
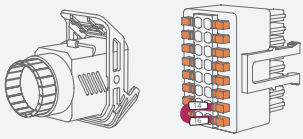
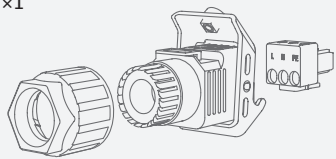
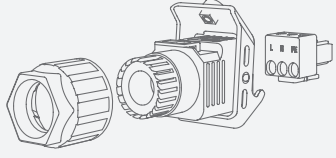

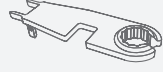

## NOTICE

- Check if the deliverables are intact and complete. If any item is missing or damaged, contact the supplier.
- Retain the original packaging and documentation for further needs.

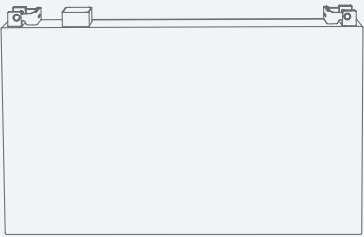

### • ECOFLOW POWEROCEAN HYBRID INVERTER

<p><b>A1</b> ×1</p>  <p>EcoFlow PowerOcean Hybrid Inverter</p>	<p><b>A2</b> ×1</p>  <p>EcoFlow IOT Dongle ESS</p>	<p><b>A3</b> ×2</p>  <p>PV terminals</p>		
<p><b>A4</b> ×2</p>  <p>Communication connectors</p>	<p><b>A5</b> ×1</p>  <p>COM connector with shorting wire</p>	<p><b>A6</b> ×1</p>  <p>Grid connector</p>		
<p><b>A7</b> ×1</p>  <p>Backup connector</p>	<p><b>A8</b> ×5</p>  <p>Screws(M5*12)</p>	<p><b>A9</b> ×2</p>  <p>PV Disassembly and Assembly Tool</p>	<p><b>A10</b> ×2</p>  <p>OT terminal</p>	<p><b>A11</b> ×7</p>  <p>Tubular Terminal (For wire gauge 10AWG/6mm<sup>2</sup>)</p>
<p><b>A11</b> ×5</p>  <p>Tubular Terminal (For wire gauge 18AWG/1mm<sup>2</sup>)</p>	<p><b>A12</b> ×3</p>  <p>Tubular Terminal (For wire gauge 26AWG/0.25mm<sup>2</sup>)</p>			

### • ECOFLOW POWEROCEAN LFP BATTERY

<p><b>B1</b> ×1</p>  <p>EcoFlow PowerOcean LFP Battery</p>	<p><b>B2</b> ×2</p>  <p>Battery T-shaped mounting piece(M6) Battery L-shaped mounting piece</p>	<p><b>B3</b> ×8</p>  <p>Screws(M5*12)</p>	<p><b>B4</b> ×2</p>  <p>Expansion bolt(M6*60)</p>
--	--	---	--

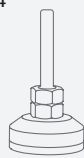
### • ECOFLOW POWEROCEAN LFP BATTERY BASE

<p><b>C1</b> ×1</p>  <p>Battery base</p>	<p><b>C2</b> ×4</p>  <p>Adjustable feet</p>	<p><b>C3</b> ×2</p>  <p>Expansion bolt(M6*60)</p>	<p><b>C4</b> ×1</p>  <p>Marking-off template for battery</p>
--	--	--	--

# System Installation

## Installation Environment Requirements

**WARNING**

- The installation and use environment must meet relevant international, national, and local standards for lithium batteries, and are in accordance with the local laws and regulations.

**NOTICE**

- When installing the equipment in a garage, keep it away from the drive way.
- The mounting structure where the equipment is installed must be fire resistant. Do not install the equipment on flammable building materials.
- Ensure that the installation surface is solid enough to bear the weight of the equipment.

**AVOID DIRECT SUNLIGHT, RAIN, OR SNOW**

**WELL-VENTILATED AREA ONLY**

**VERTICAL POSITION**

**AVOID UNEVEN GROUND**

**AVOID PIPES & CABLES & REINFORCING BAR**

**IP65**

0%-100% RH

-20°C -50°C

**ALTITUDE**

≤3000 m

**DISTANCE FROM THE SEA**

>500 m

**AWAY FROM**

Solvent

Gasoline

Heat source

Moisture

Explosive material

Flammable material

Infrared radiation

**AWAY FROM CHILD & WORKING & LIVING AREAS**

**NOT INTENDED FOR MOBILE SCENARIOS**

**NOT INTENDED FOR IMPORTANT DEVICES**

## Installation Space Requirements

**WARNING**

- Reserve enough clearance around equipments to ensure sufficient space for installation and heat dissipation.

**NOTICE**

- Ensure there is enough space on both sides of the battery to facilitate the locking operation of the screws on the side of the battery.

**Dimensions and Weight:**

- Top view: 680 mm (width), 732 mm (height)
- Side view: 280 mm (depth)
- Weight: 21.5kg (top section), 55.5kg (bottom section), 5.1kWh (capacity)
- Height: 1129 mm (total), 1525 mm (middle section)
- Capacity: 10.2kWh (middle section), 15.3kWh (bottom section)
- Depth: 183 mm

**Clearance Requirements:**

- Top: ≥300 mm
- Bottom: 65-85 mm
- Left and Right sides: ≥300 mm

# Installing Battery

## ⚠ DANGER

- When drilling holes, avoid the water pipes and power cables buried in the wall and under the floor.
- When drilling holes, protect the battery base from shavings or dust.
- Before installing the battery, make sure that the click-on terminals on the top and bottom of the battery are free of foreign objects or any liquid.

## ⚠ CAUTION

- Assign enough personnel (two or more) to move battery to avoid personal injury and battery damage.
- When moving battery, hold handles on top of the battery module.

## NOTICE

- Sealant is applied underneath the battery base to ensure its resistance against water.
- There will be a gap between the battery junction box and the battery pack before the screws are tightened. This gap is caused by the mechanical design to meet the IP rating, and will normalize after the screws are tightened.
- **(Optional) Install the provided adjustable feet to the base if needed.** Then you can adjust the level and check the level on the base to ensure that the base is placed horizontally, screw the nuts of the four feet to the top to lock.

### • WITH ADJUSTABLE FEET

**1** C1  x1 C2  x4

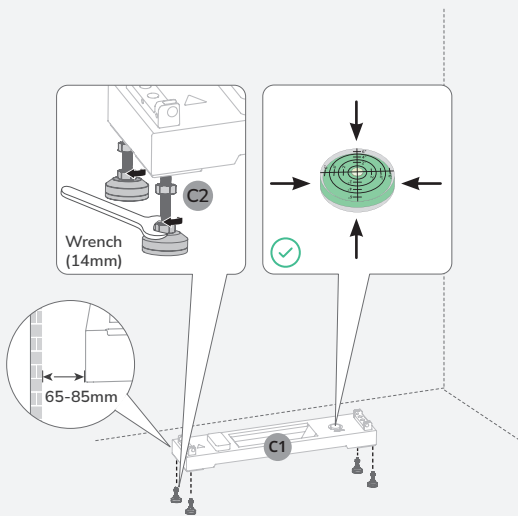

**2**

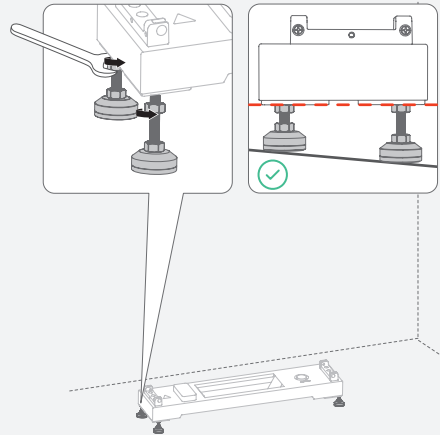

**3** C4  x1

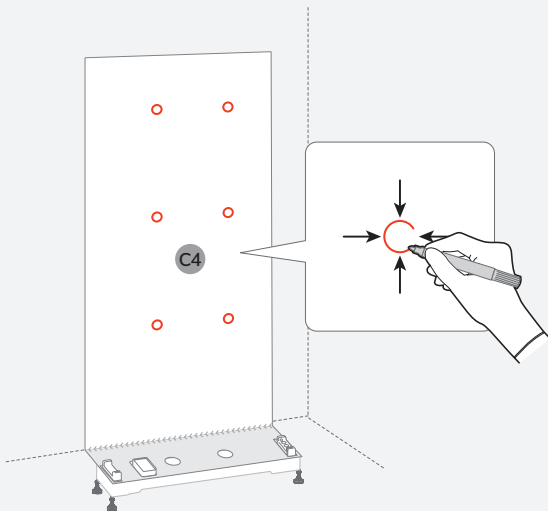

**4**

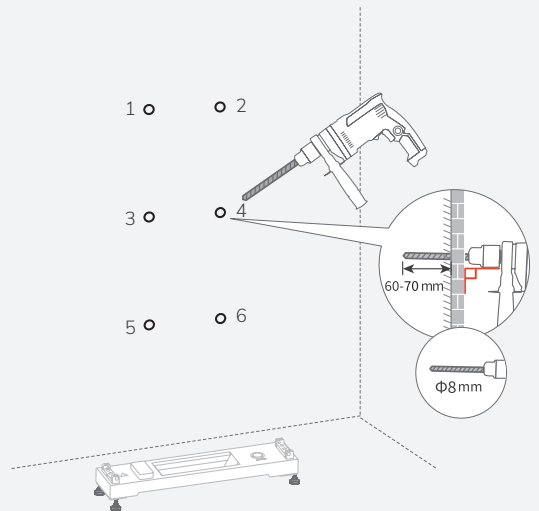

• WITHOUT ADJUSTABLE FEET

**1** C1

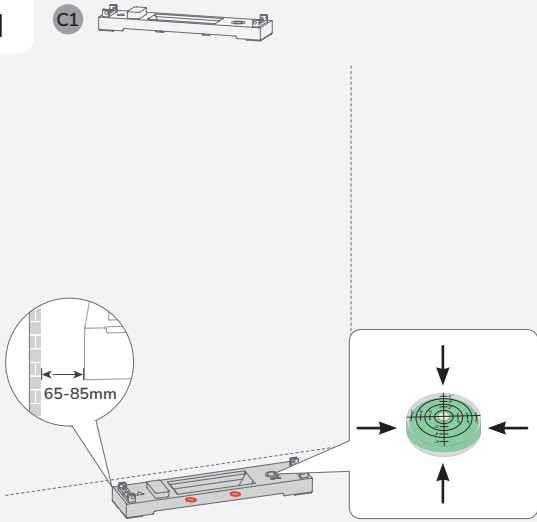

**2** C4 x1

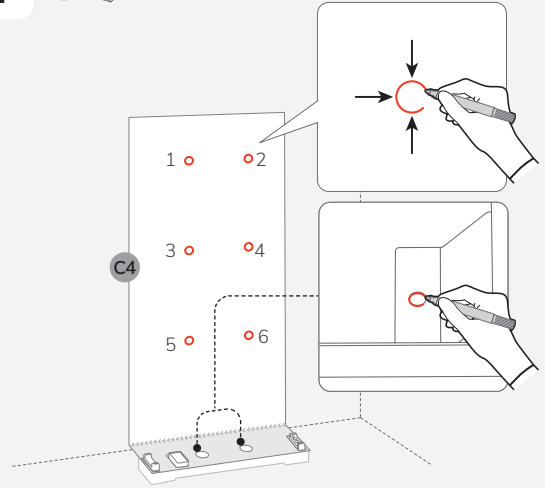

**4**

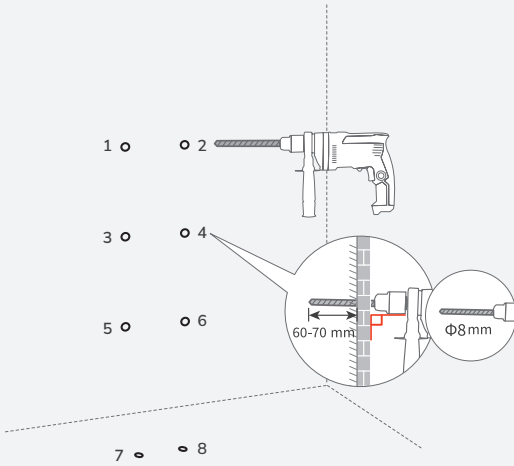

**5**

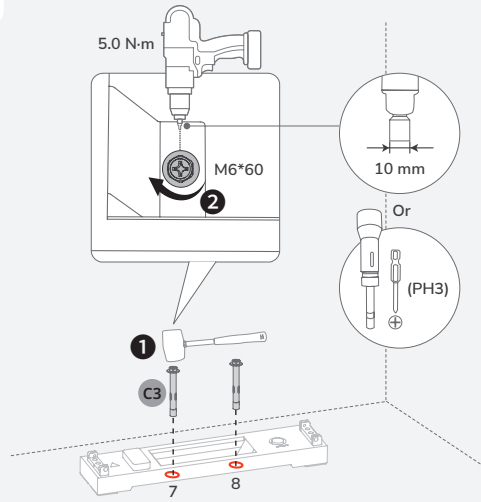

**6** B1 x1 B2 x2 B3 x4

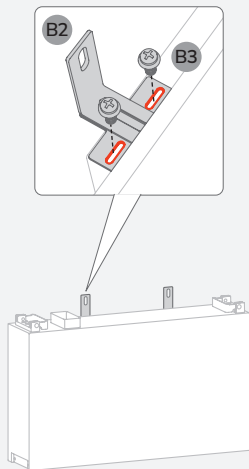

**7** B3 x4

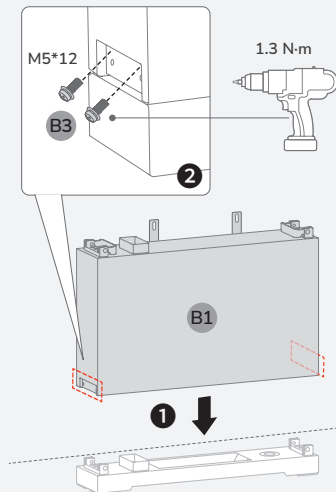



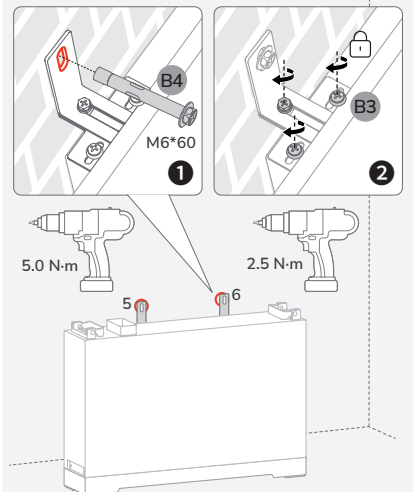

**8** B4 x2







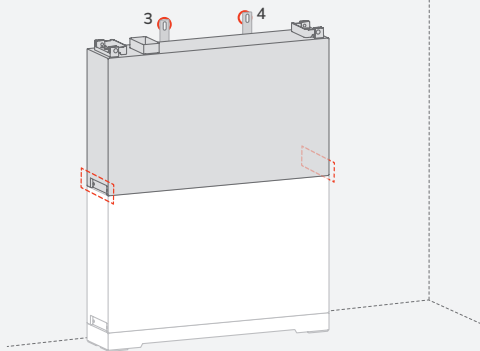

9

B1  x1 B2  x2 B3  x4 B4  x2



10

B1  x1 B2  x2 B3  x4 B4  x2

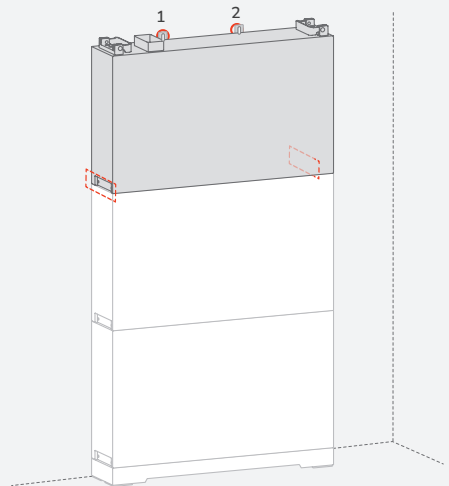

### Installing Inverter

1

A1  x1

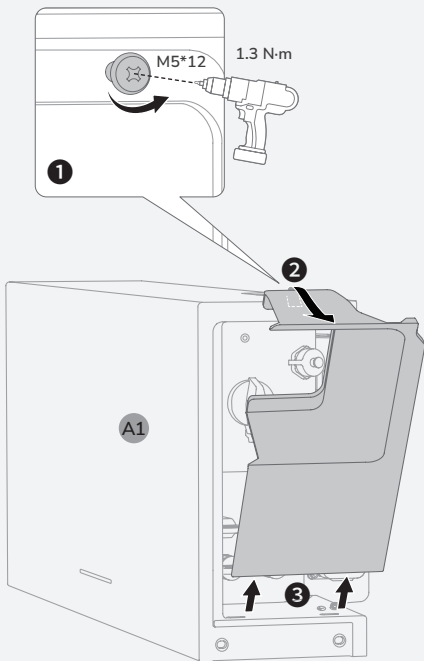

2

A8  x4

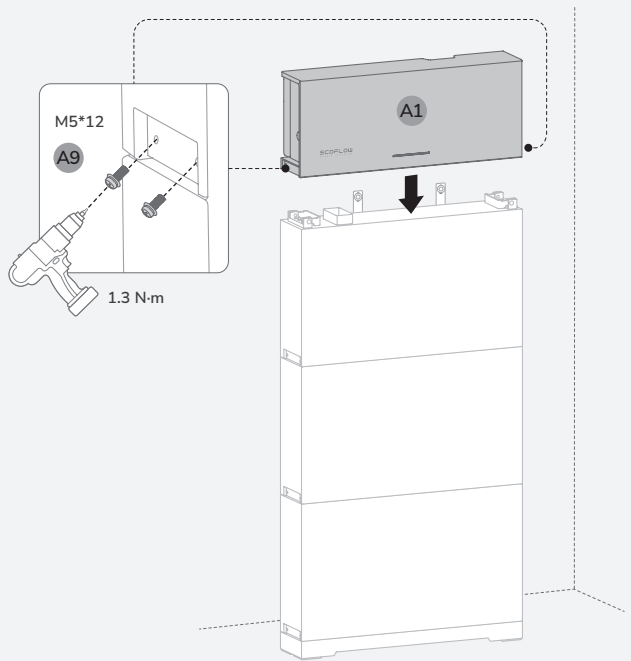

# Electrical Connection

**CAUTION**

**NOTICE**

- All electrical connections must be carried out by a professionally trained and certified electrician.
- Please purchase cables that meet local certification standards.
- Do not remove the protective cap of unused terminals. Otherwise, the IP rating of the inverter will be affected.
- The cable colors shown in the figures are for reference only. Select an appropriate cable according to the local standards.

## System Overview

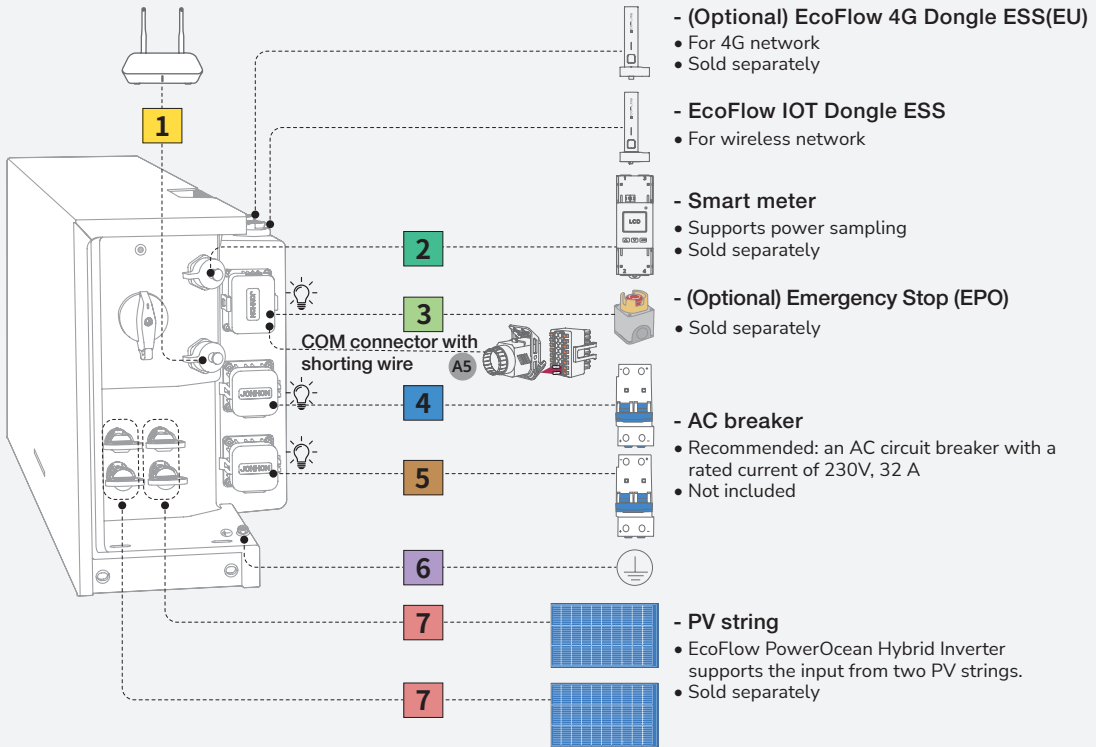
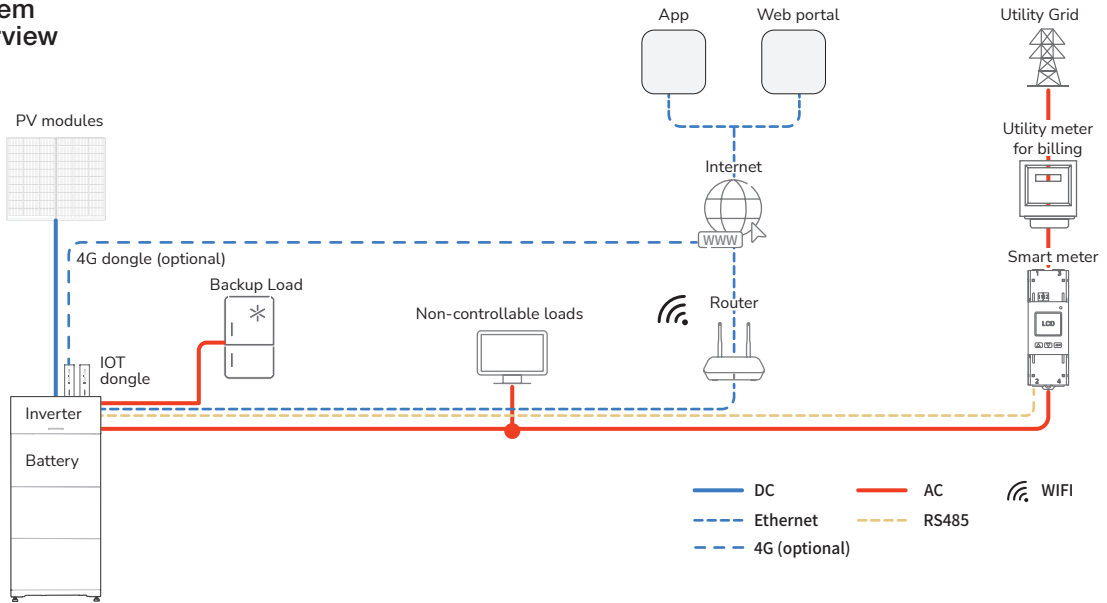

**1 Ethernet cable (optional)**  
Cat 5e or higher shielded network cable

**2 Smart meter communication cable**  
CAT 5E 8\*0.2mm<sup>2</sup>

**3 COM terminal communication cable-EPO (optional)**  
Shielded Twisted Pair 2\*0.5mm<sup>2</sup>

**4 Backup cable**  
6 mm<sup>2</sup> to 8 mm<sup>2</sup>

**5 Grid cable**  
6 mm<sup>2</sup> to 8 mm<sup>2</sup>

**6 PE cable**  
6mm<sup>2</sup>

**7 PV Input cable**  
Conductor cross-sectional area: 4 mm<sup>2</sup> to 6 mm<sup>2</sup> with a rated voltage greater than or equal to 1000V DC

Connectors with JONHON trademark supplied by Avic Jonhon Optronic Technology Co., Ltd.

**NOTICE**

- N and PE wiring via GRID and BACKUP ports of the inverter vary based on the regulation requirements of different regions. Refer to the specific requirements of local regulations.

**a. N and PE cables are connected together in the Main Panel for wiring.**

**NOTICE**

- For Australia and New Zealand, the N cable of GRID side and BACK-UP side must be connected together according to the wiring rules AS/NZS\_3000. Otherwise BACK-UP function may be abnormal and risky.
- A single-pole double-throw switch (SPDT for short) is recommended to be configured on the BACK-UP side for convenient maintenance.
- The following diagram is applicable to areas in Australia, New Zealand, etc.

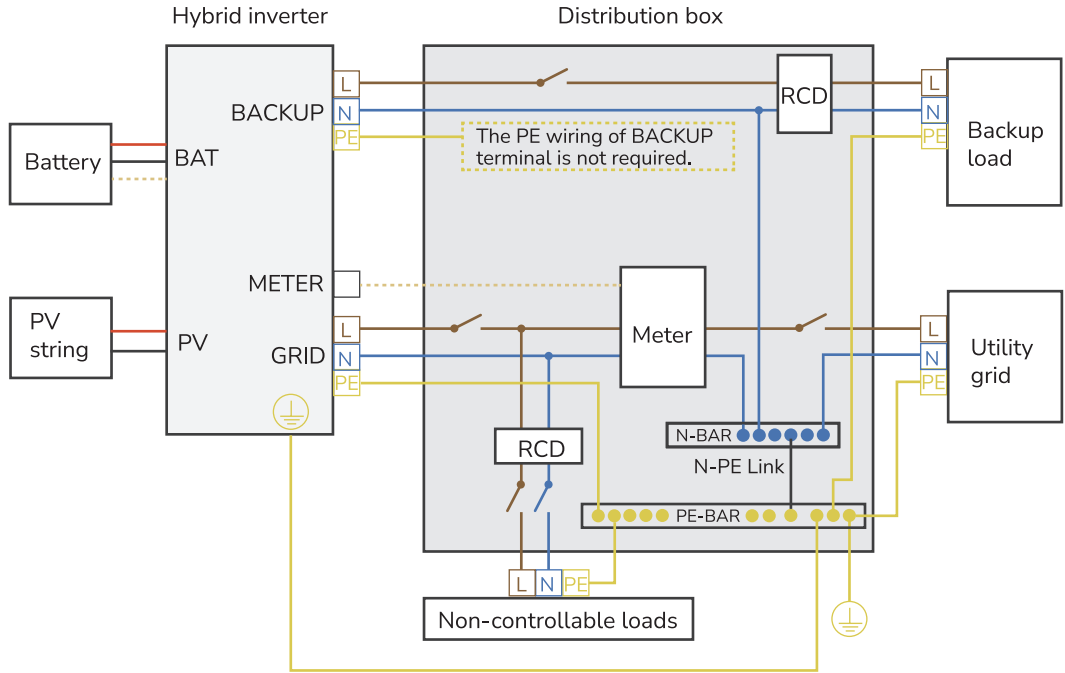

**b. N and PE cables are separately wired in the Main Panel.**

**NOTICE**

- The following diagram is applicable to other countries whose grid systems without special requirement on wiring connection.
- A double-pole double-throw switch (DPDT for short) is recommended to be configured on the BACK-UP side for convenient maintenance.

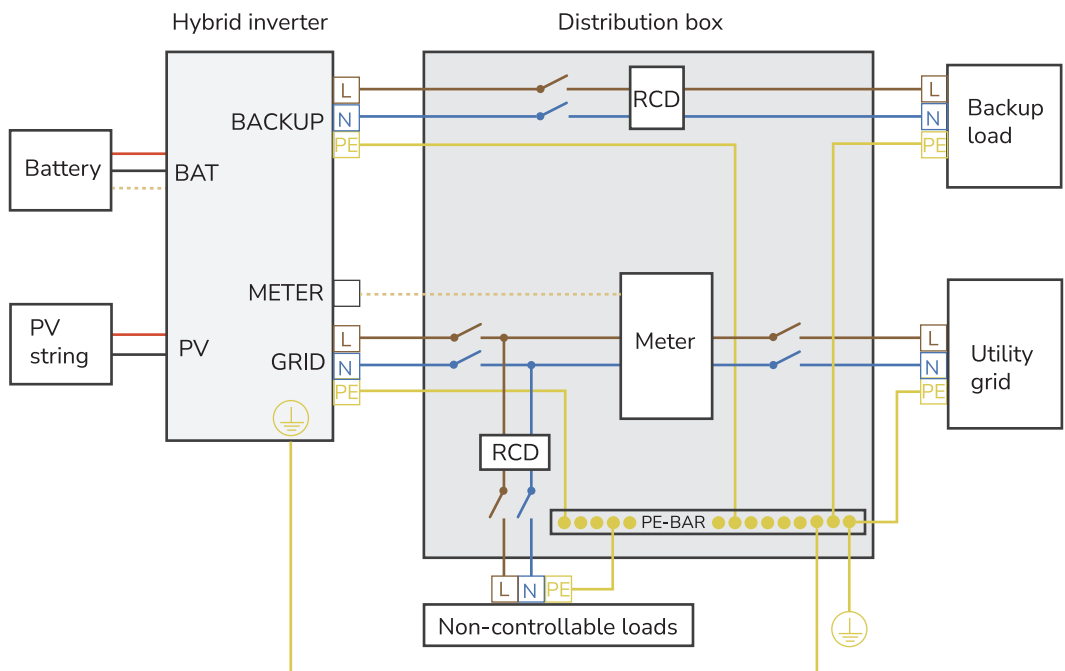

## Connecting PE Cables

### NOTICE

- Ensure that the PE cable is connected securely.
- Wrap the wire crimping area with heat shrink tubing or insulation tape. The heat shrink tubing is used as an example.
- When using a heat gun, protect the equipment from being scorched.
- It is recommended that silica gel or paint be used around the ground terminal after the PE cable is connected.

1  ×1

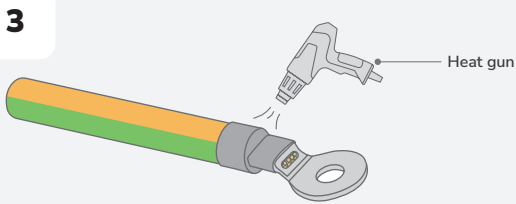
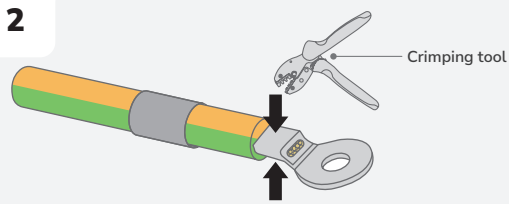
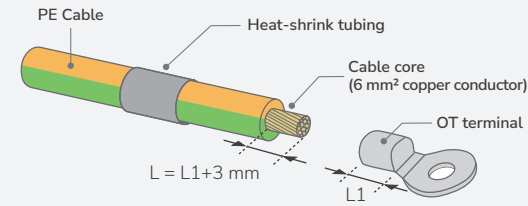

4

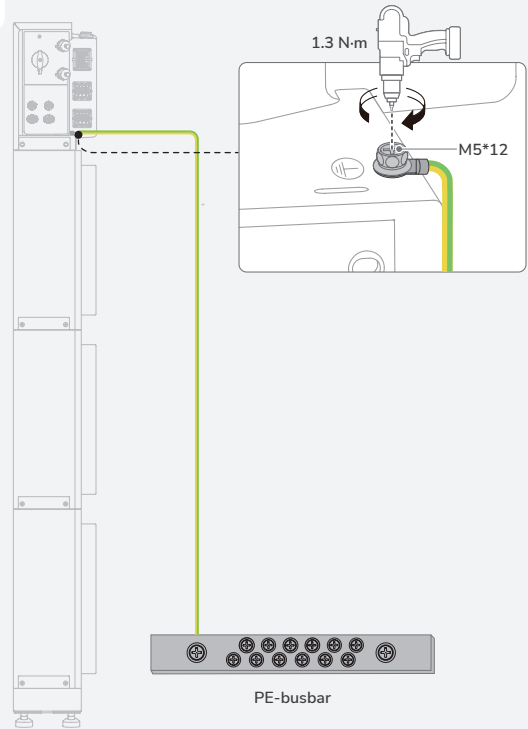

## Connecting GRID Cables

### CAUTION

- Before installing, operating, and maintaining the equipment, always disconnect it from all power.
- Do not connect loads between the inverter and the AC switch that directly connects to the inverter.
- Ground the PE hole of GRID connector and the equipment enclosure.
- Do not connect the GRID connector to the BACKUP terminal of the inverter.

### NOTICE

- RCD with rated residual operating current of 100 mA (AC-GRID) and 30mA (AC-BACKUP) would be recommended if there is additional protection by RCD shall be provided for local electrical installation, while the use of an RCD with lower rated residual operating current is also permitted if it is required by the specific local electrical codes.

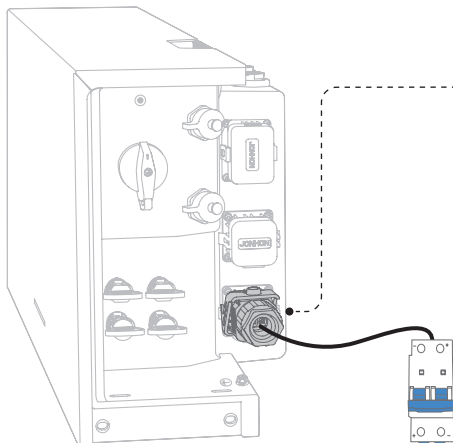

### GRID terminal

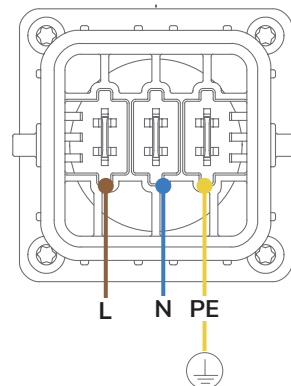

L · Live line  
N · Neutral wire  
PE · Ground wire

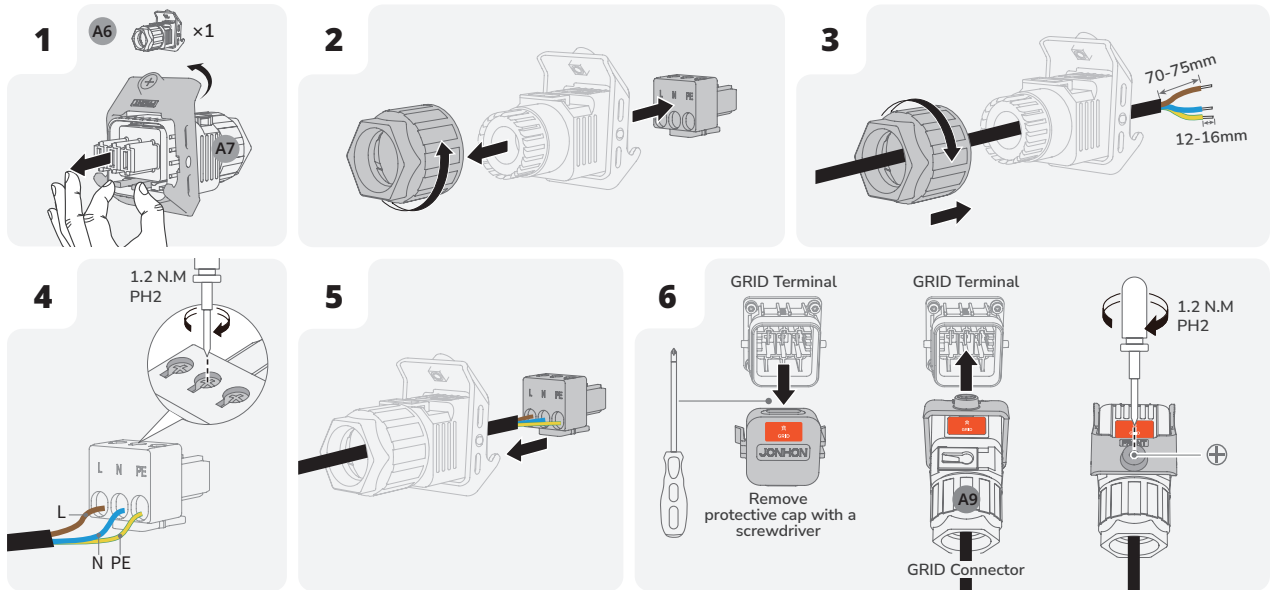

## Connecting BACKUP Cables

### ⚠ CAUTION

- Before installing, operating, and maintaining the equipment, always disconnect it from all power.
- Do not connect the BACKUP connector to the GRID terminal of the inverter.
- It is not recommended to connect loads with high starting power to BACKUP terminal, such as vacuum cleaner, air conditioner, etc.

### NOTICE

- RCD with rated residual operating current of 100 mA (AC-GRID) and 30mA (AC-BACKUP) would be recommended if there is additional protection by RCD shall be provided for local electrical installation, while the use of an RCD with lower rated residual operating current is also permitted if it is required by the specific local electrical codes.

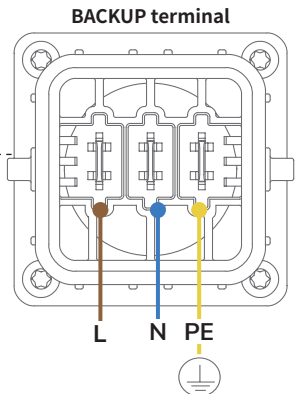
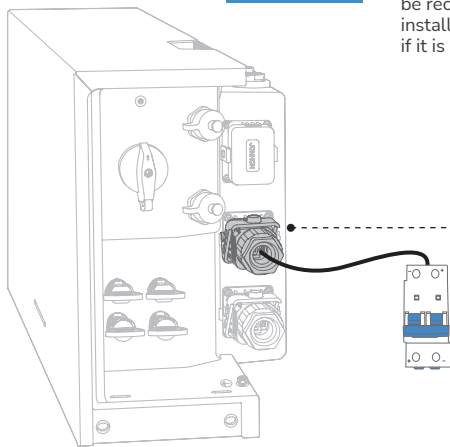

L · Live line  
 N · Neutral wire  
 PE · Ground wire

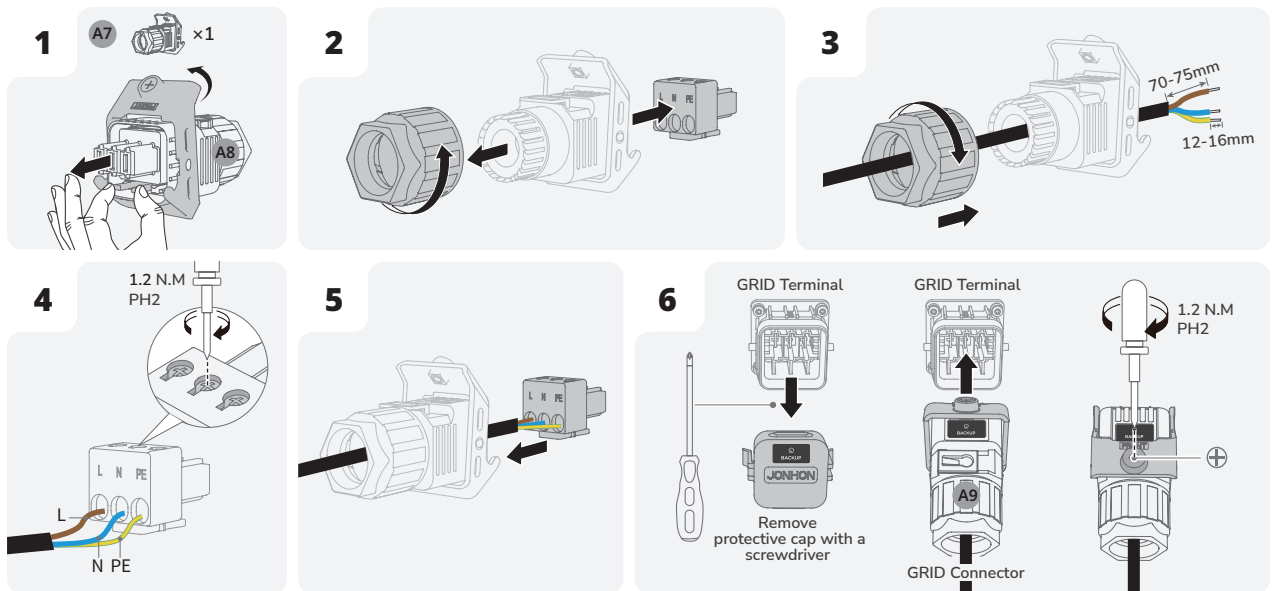

# Installing COM Connector With Shorting Wire

## NOTICE

- COM terminal supports logic interface connection. Logic interface is required by some local regulations that can be operated by a simple switch or contactor.
- When the switch is closed, the inverter can operate normally. When the switch is opened, the inverter will reduce its active power to zero within 5s.
- Pin14 and Pin16 of COM terminal is used for the logic interface connection.

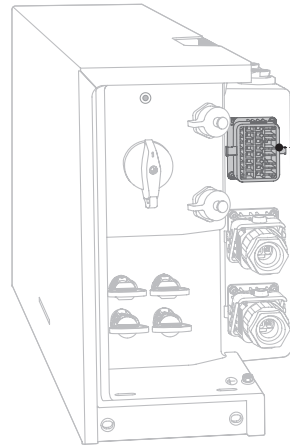

COM terminal

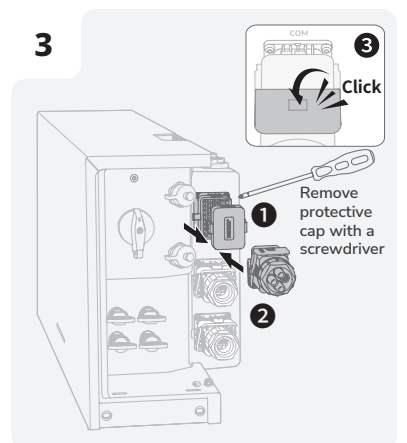
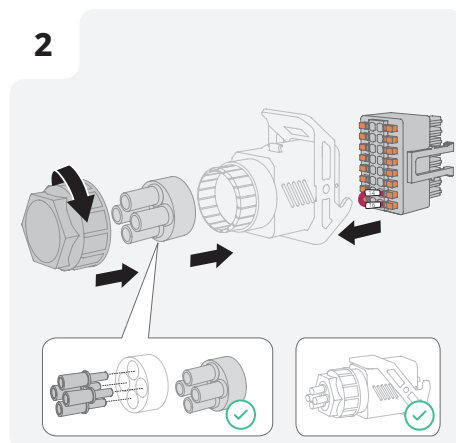
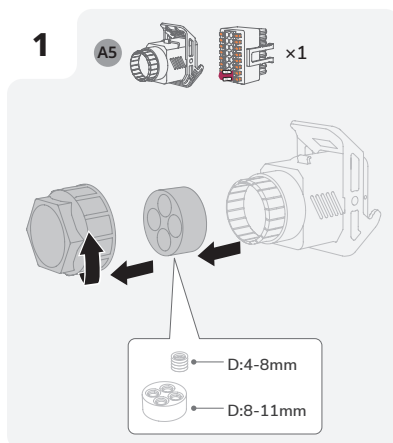
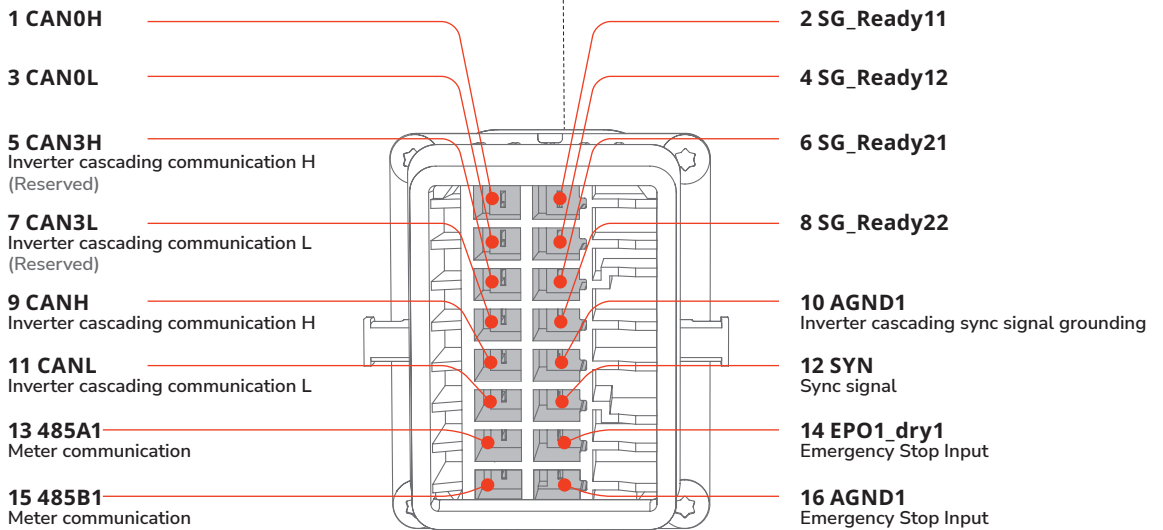

# (Optional) Installing Emergency Stop (EPO)

## NOTICE

- Before installing EPO, please remove the shorting wire between PIN14 and PIN16.
- For more details about Emergency Stop, please refer to its user manual.

1 **A5**  x1

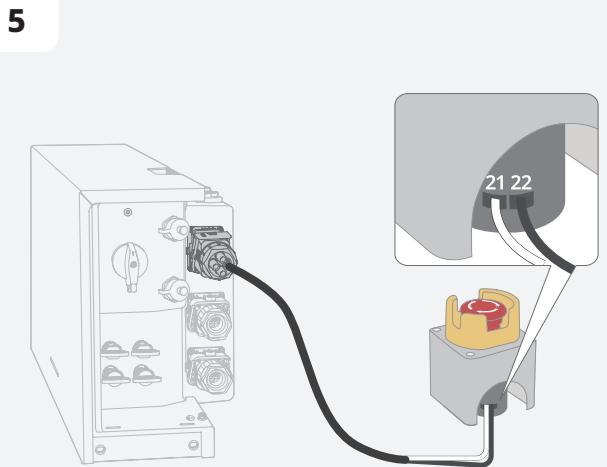
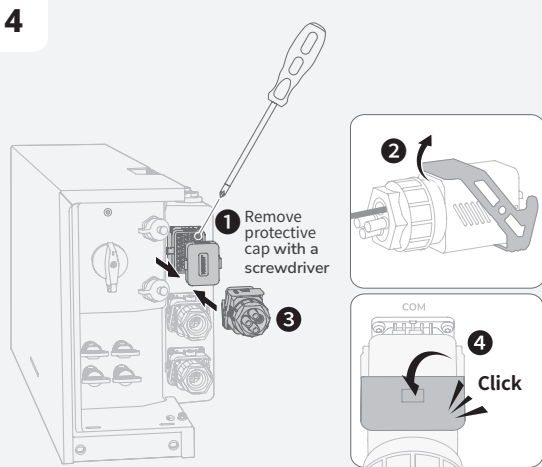
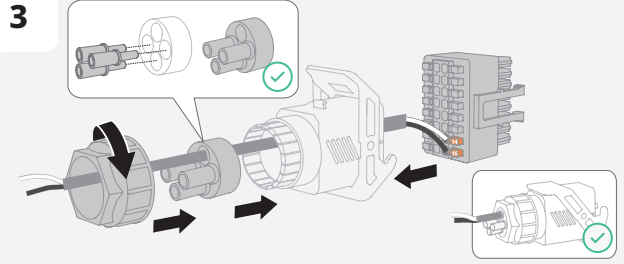
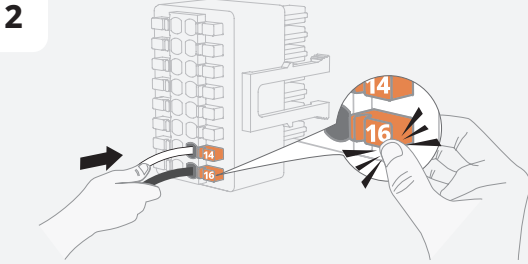
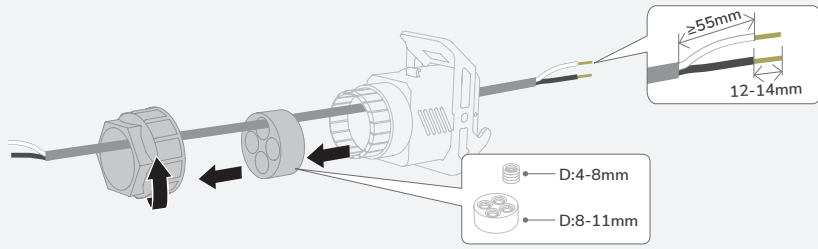

## Connecting PV Input Cables

### **⚠ DANGER**

- Before connecting the PV input cables, ensure AC switch connected to the inverter and the PV SWITCH on the inverter are OFF. Failing to do so may result in electric shocks.
- The PV string will generate lethal high voltage when exposed to sunlight. Disconnect the PV cable of PV string before connecting DC power.
- Before connection, ensure the polarity of the output of the PV array matches "PV+/"PV-" symbols.
- Before connecting the PV input cables, ensure that the impedance between the positive/negative terminals of the PV string and earth are larger than 1 MΩ. Do not ground the PV array positive/negative hole.
- When the inverter is running, it is not allowed to work on the PV input cables, such as connecting or disconnecting a PV string or a PV module in a PV string. Failing to do so may cause electric shocks.
- Do not remove Solarlok SAFE-TE Connectors of unused PV input terminal. Failing to do so may result in electric shocks.
- Ensure that the maximum DC voltage and the maximum short-circuit current of any string do not exceed the allowed range specified in the "Technical Parameters" of the User Manual.

### **NOTICE**

- In order to avoid malfunction, please do not connect any PV modules that have a risk of leakage current to the inverter.
- In order to avoid lightning damage to the inverter, it is recommended to add a surge protection switch at the PV junction box.
- After the positive and negative connectors snap into place, slightly pull the PV input cables back to ensure that they are connected securely.
- It is not recommended that connect different brands or models of PV modules to one MPPT circuit, or connect PV modules of different orientation or angles to one PV string.

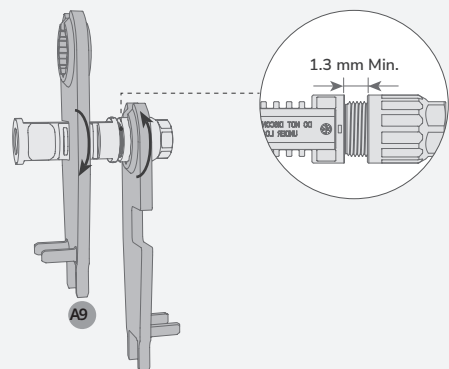
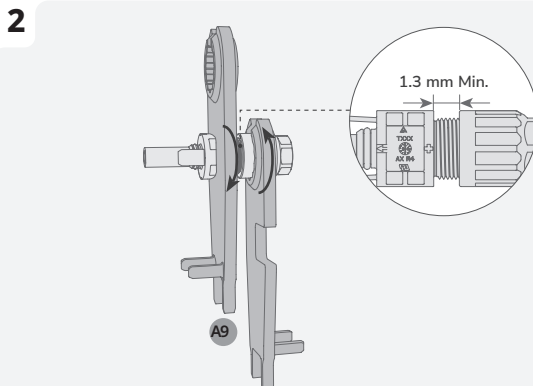
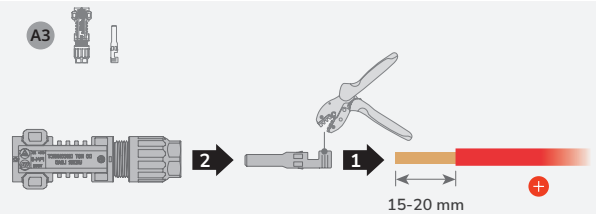
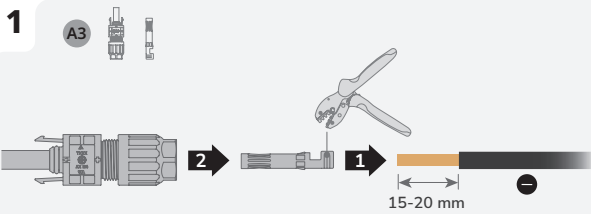
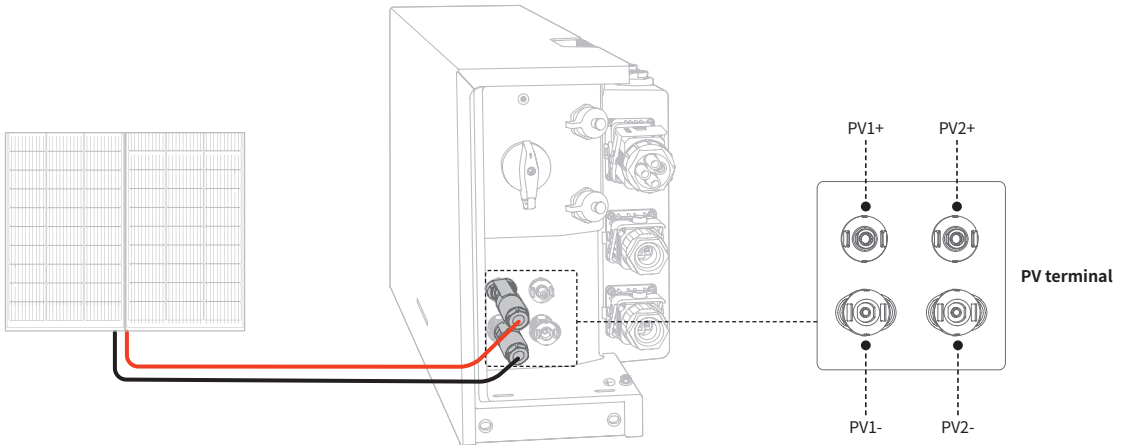



## REMOVE SOLARLOK SAFE-TE CONNECTORS

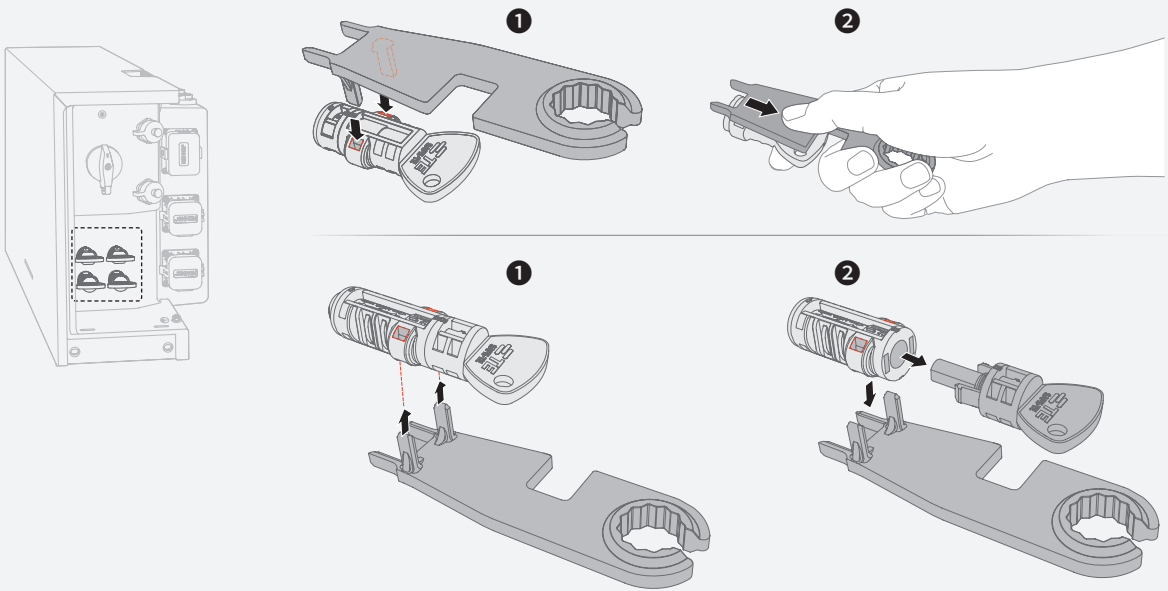

## CONNECT TO THE INVERTER.

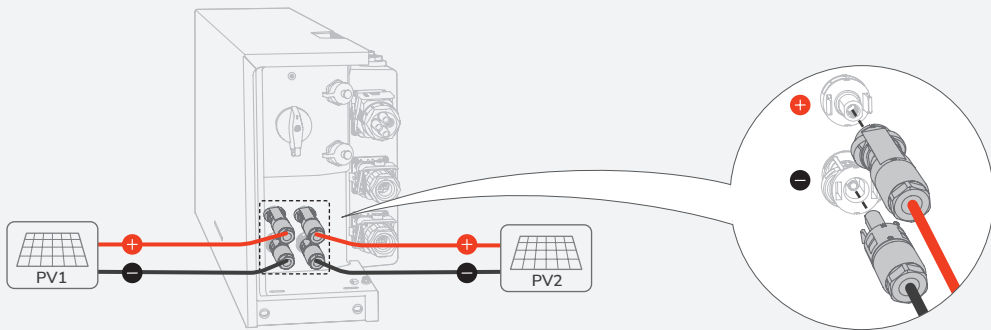

💡 Set the multimeter to DC gear to measure the voltage at the DC position. If the voltage is a negative value, the PV input polarity is incorrect and needs correction. If the voltage is greater than 1000 V, too many PV modules are configured to the same string. Remove some PV modules.

If the PV input cable is reversely connected and the PV SWITCH is set to ON, first set the PV SWITCH to the OFF position, then remove the positive and negative connectors, and correct the polarities of the PV input cables.

## REMOVING THE PV TERMINAL



**WARNING**

- Before removing the positive and negative connectors, ensure that the PV SWITCH is OFF.

A9 ×1

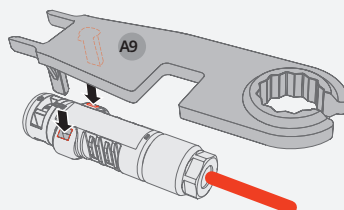

# Connecting Smart Meter

## NOTICE

- It is recommend to use of CAT5 or higher rating network cable.
- Smart meter is sold separately, which has been preset parameters before delivered. Do not modify the relevant parameters.
- The compatibility of this product with smart meters may vary by regions and versions. For detailed instructions on the installation and wiring scheme of the smart meter for this product, please refer to the guide that comes together with the meter.

### SMART METER INSTALLATION

- METER SAMPLING**  
Access the home main road and connect the smart meter as shown in the diagram.
- METER COMMUNICATION**  
Connect communication port 11, 12 on the meter to the METER port of inverter.

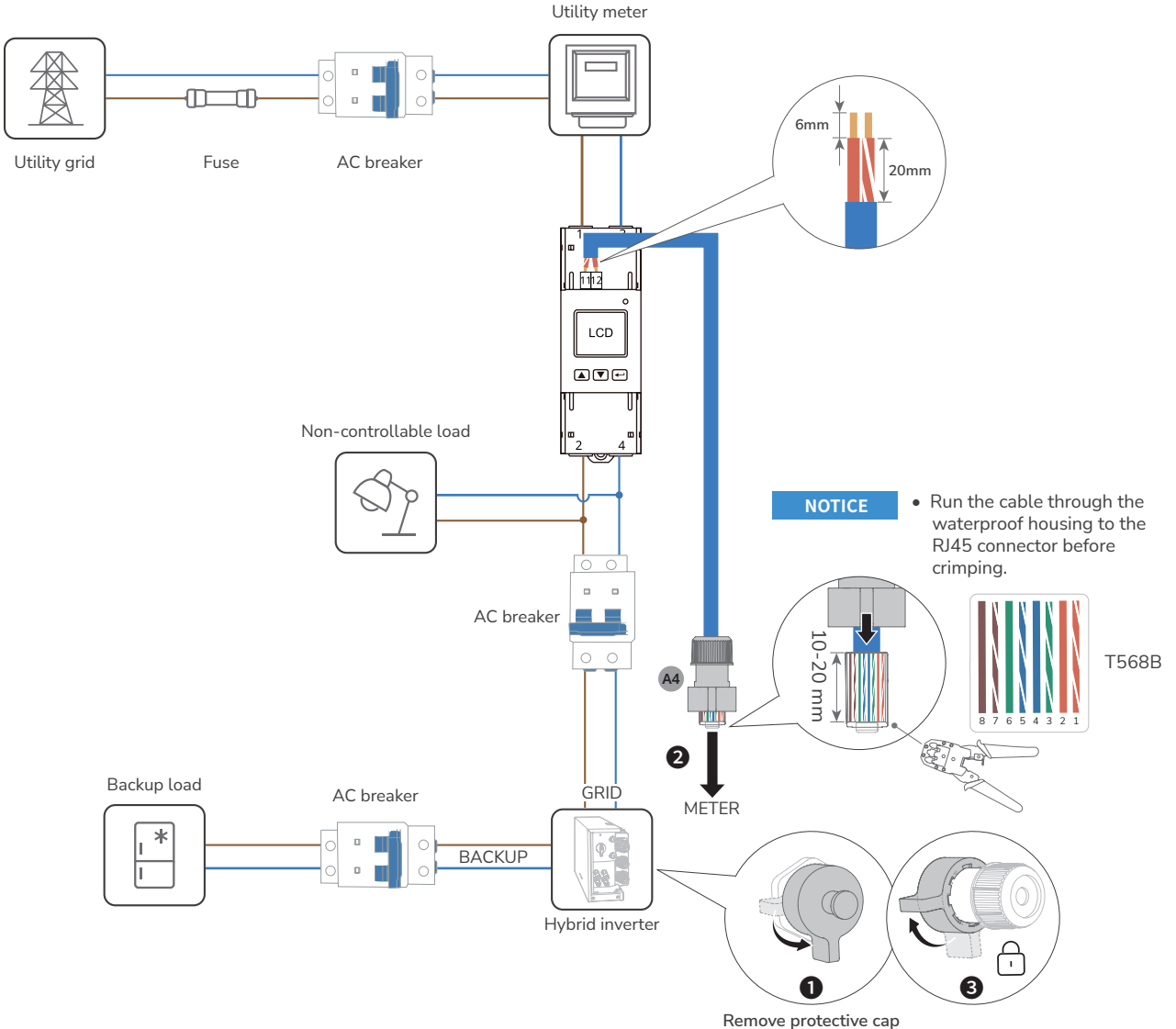
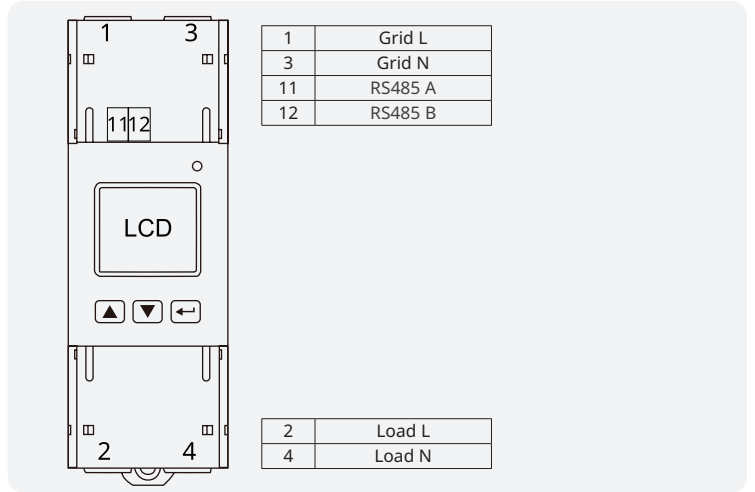

## SMART METER (WITH CT) INSTALLATION

- 1 METER SAMPLING**  
Access the home main line and connect the smart meter as shown in the diagram.
- 2 METER COMMUNICATION**  
Connect communication port A, B on the meter to the METER port of inverter.

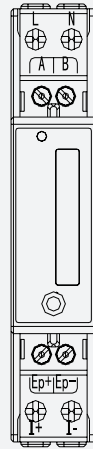

L	Grid L
N	Grid N
A	RS485 A
B	RS485 B

I+	Grid L CT
I-	

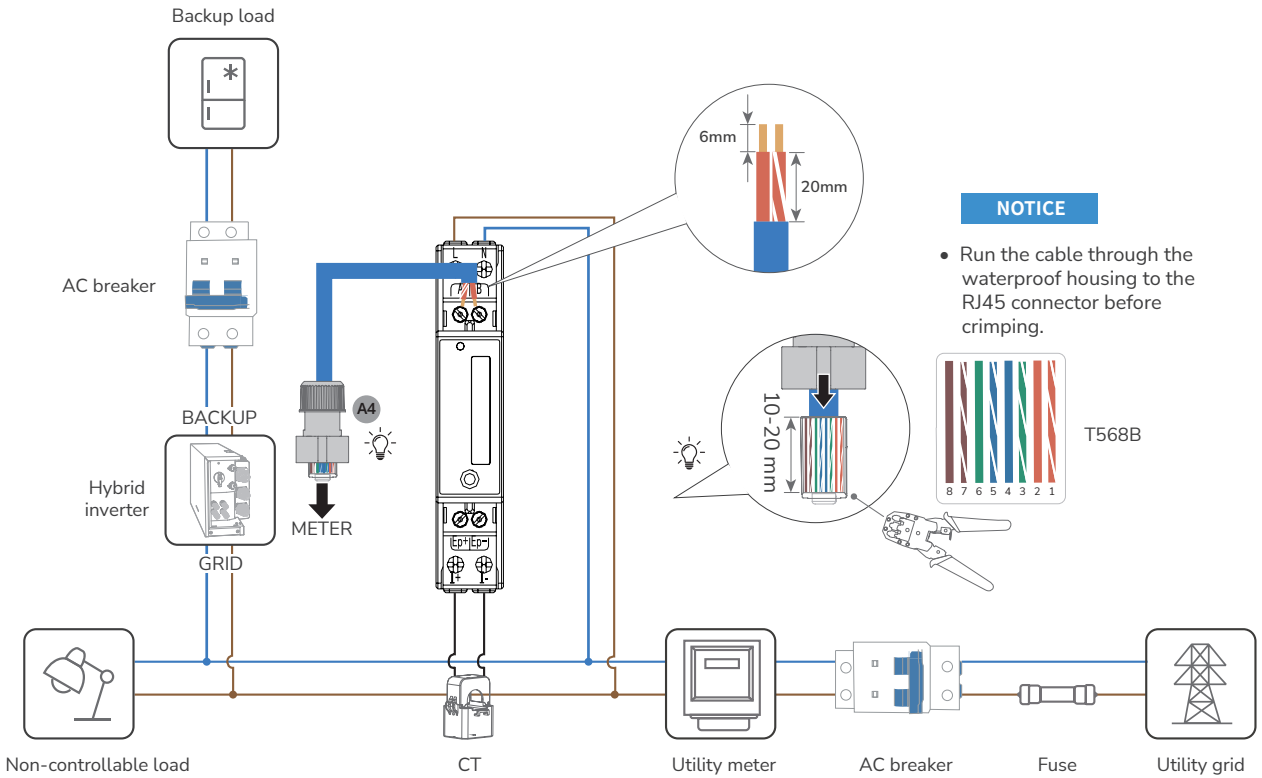

# Connecting to Internet

**NOTICE**

- Use shielded CAT 5 or higher rating network cable for stable connection.

• **METHOD 1: VIA A WIRED NETWORK**

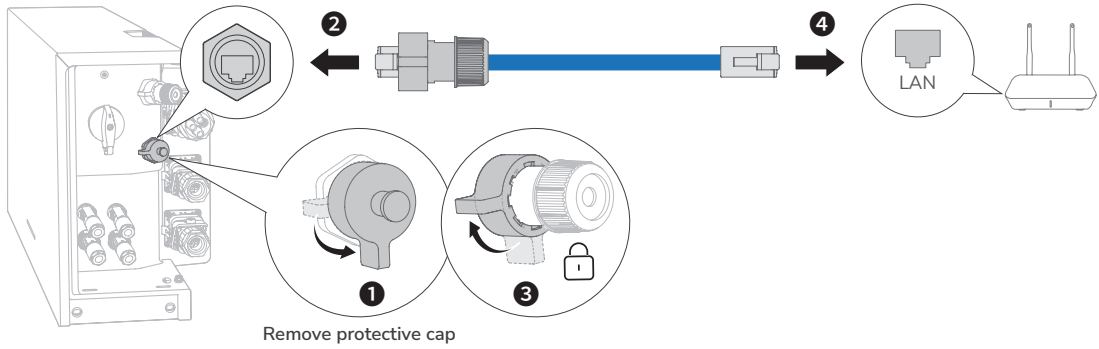

**1** A4 x1

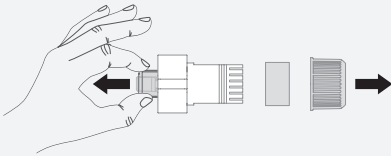

**2** Both ends of the network cable use the T568B wiring standard.

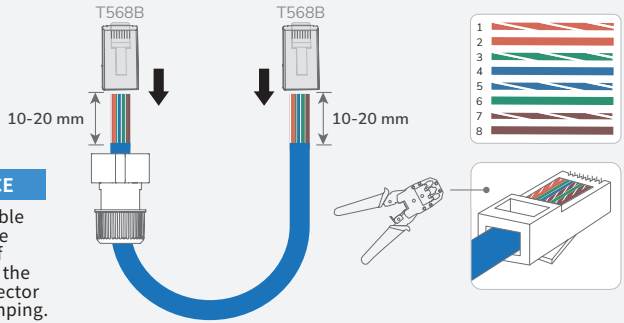

**3** Test network cable connection. If the LEDs of the two RJ45 ports light up in sequence, it indicates that the network cable is correctly wired and should be fully operational.

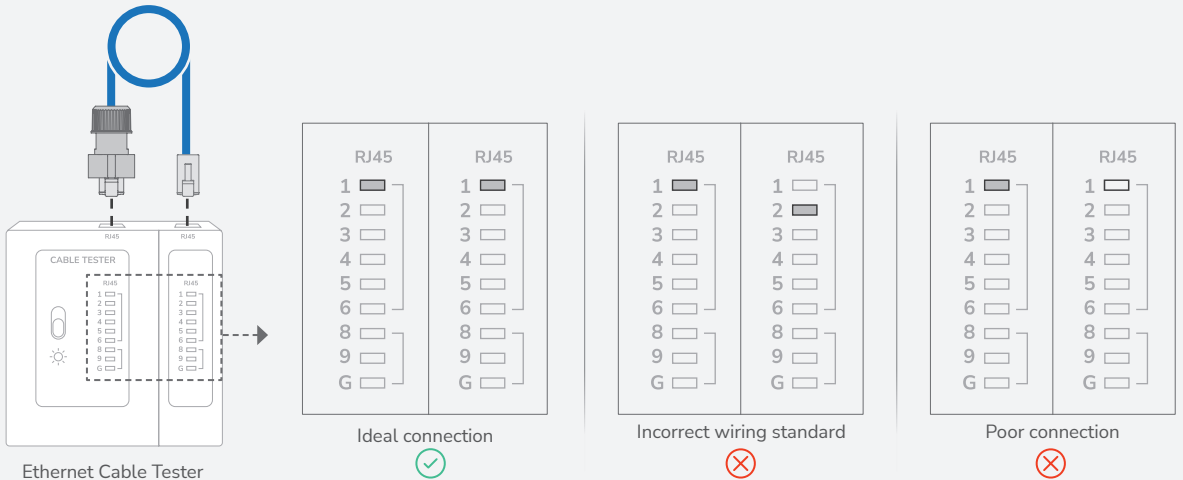

• **METHOD 2: VIA A WIRELESS NETWORK**

Refer to the System Commissioning section in this guide to connect to a wireless network.

## Installing trim cover

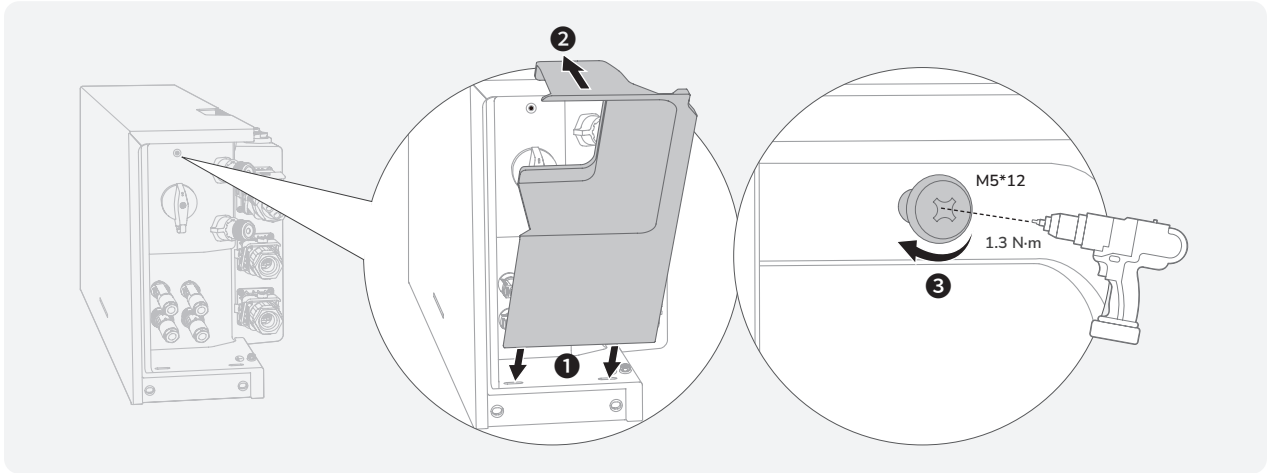

## Installing EcoFlow IOT Dongle ESS

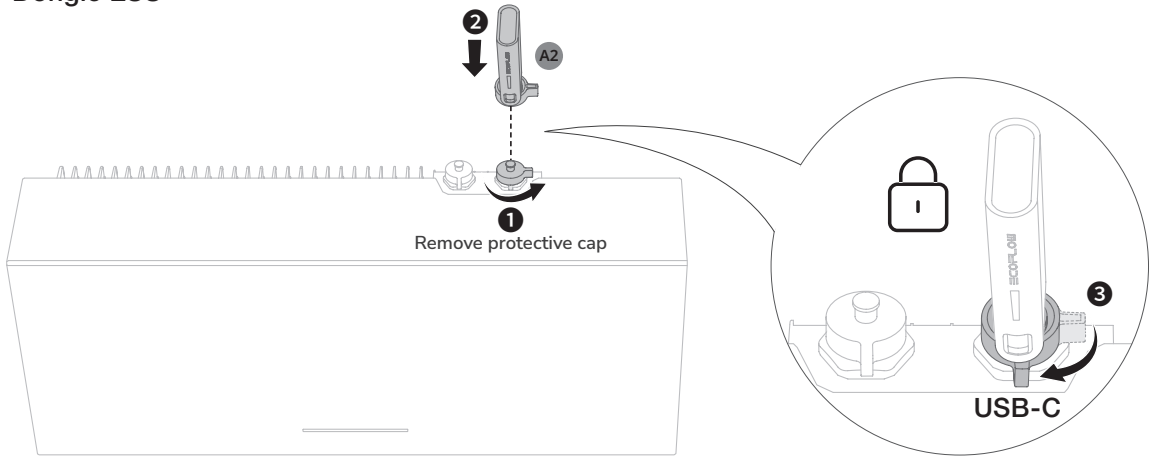

## (Optional) Installing EcoFlow 4G Dongle ESS(EU)

### NOTICE

- For more details about EcoFlow 4G Dongle ESS(EU), please refer to its user manual.

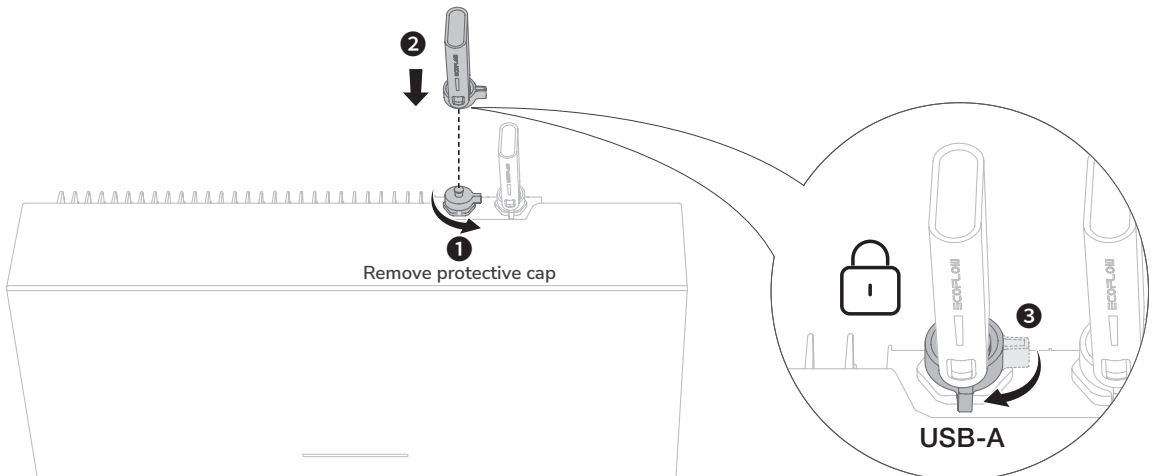

# System Commissioning

## Checking before Power-On

Check Item	Acceptance criteria
Equipments	Equipments are installed correctly and securely.
Cables routing	Cables are routed properly as required by the customer.
Cable tie	Cable ties are evenly distributed and no burr exists.
Grounding	The PE cable is connected correctly, securely, and reliably.
Switch	All the switches connecting to the system are OFF.
Cable connection	The AC/DC power cable, battery cable, and communication cable are connected correctly, securely, and reliably.
Unused terminal and port	Unused terminals and ports are locked by watertight covers.
Installation environment	The installation space is proper, and the installation environment is clean and tidy.

## System Power-On

### PROCEDURE (ON-GRID AND PV MODULE CONFIGURED)

1. Turn on the AC switch between the inverter and the power grid.
2. Set the PV SWITCH on the side of the inverter to ON position.
3. Observe the LED to check the inverter operating status.

### PROCEDURE (OFF-GRID AND NO PV MODULE CONFIGURED)

1. Turn on the AC switch between the inverter and the power grid.
2. Set the PV SWITCH on the side of the inverter to ON position.
3. After commissioning, press and hold for 5 seconds the BATTERY ON/OFF button.
4. Observe the LED to check the inverter operating status.

## System Power-Off

### ⚠ WARNING

Before installing, operating, and maintaining the equipment, always disconnect it from all power.

1. Send a shutdown command on the App.
2. Turn off the AC switch between the inverter and the power grid.
3. Set the PV SWITCH on the side of the inverter to OFF position.
4. (Optional) Secure the PV SWITCH with a lock to prevent accidental startup. The lock is prepared by the customer.
5. Press and hold the BATTERY ON/OFF button of the junction box for 10 seconds, until the indicator is off.
6. Sequentially disconnect GRID cables, BACKUP cables, PV input cables, communication cables and all modules connecting to the system.

## LED Indicators

LED Indicator	Symbol Conventions	
ON		Steady White
		Blinking White
		Carousel White
		Steady Orange
		Blinking Orange
OFF		OFF

Power On/Off Status	Description
	System startup
	System shutdown

Charge Status	Description
	0-25%
	25-50%
	50-75%
	75-99%
	100%

Discharge/Standby Status	Description
	<5%
	5-25%
	25-50%
	50-75%
	75-100%

Over-the-air Updates Status	Description
	Over-the-air update is in progress

Faulty Status	Description
	Abnormal electrical connection. Check if all equipment is installed correctly and securely.
	Abnormal smart meter communication.
	Abnormal IoT communication.
	Battery is faulty.
	Abnormal battery communication.
	Converter is faulty.
	Abnormal converter communication.

### NOTICE

- If the LED indicates a faulty status, visit the EcoFlow Pro app to retrieve the error code for troubleshooting.

# System Commissioning

## 1 DOWNLOAD AND INSTALL ECOFLOW PRO APP (FOR INSTALLER ONLY)

Scan the QR code or download at:  
<https://download.ecoflow.com/ecoflowproapp>



## 2 CREATE ACCOUNT

### a. Create company account

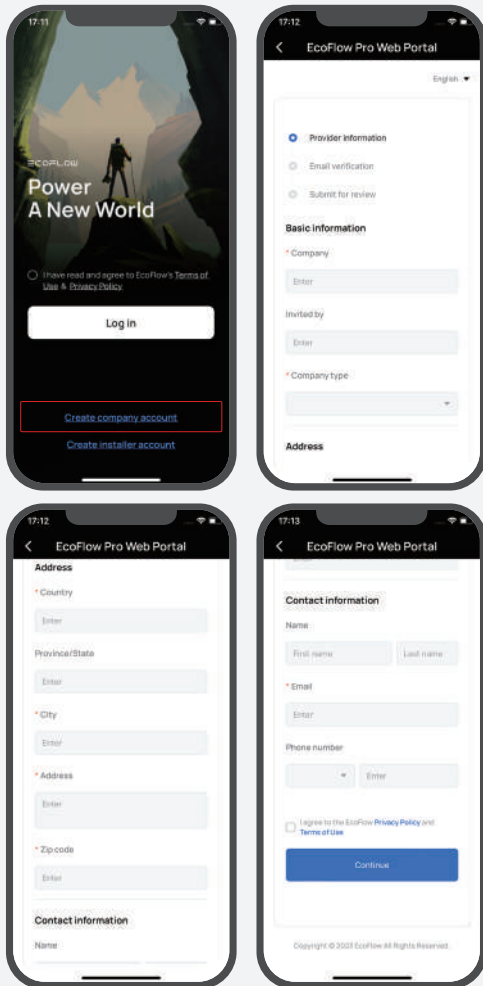

### b. Create installer account

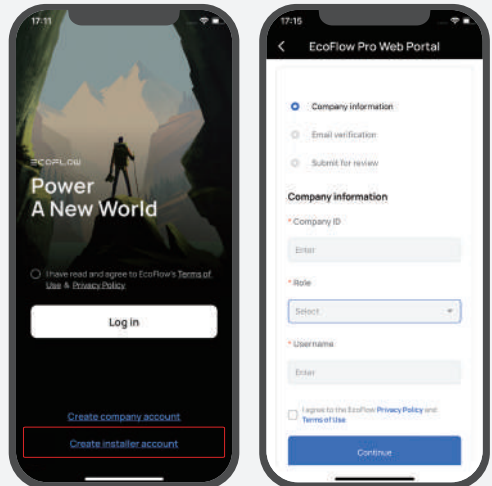

## 3 LOG IN

Enter the installer account and password.

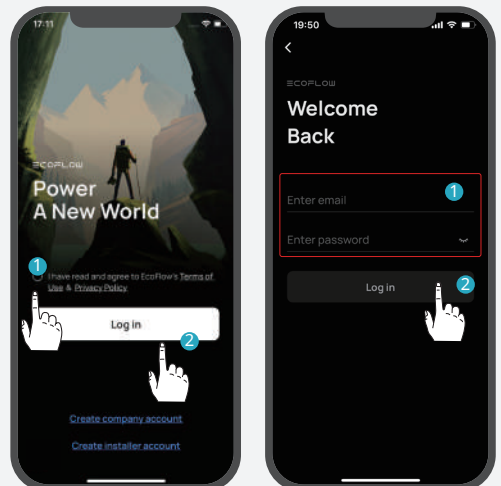

## 4 ADD DEVICE

You can connect to the system via Bluetooth or Wi-Fi.

### a. Connect to the system via Bluetooth.

Click **Add System** to automatically search for bluetooth devices nearby, and click **EcoFlow PowerOcean Single Phase** to connect, then click **Complete** to proceed.

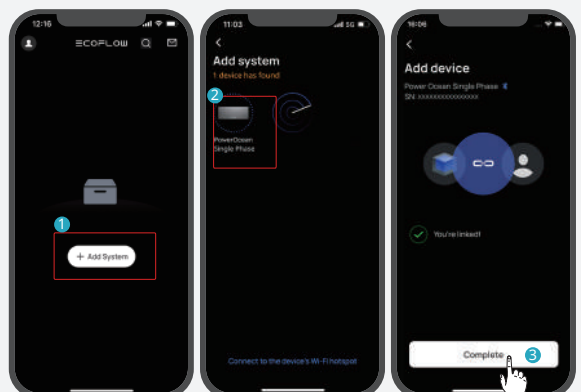

### b. Connect to the system via Wi-Fi

1. Click "Add System" and then click "Or connect to the system's Wi-Fi" to access to your phone's Wi-Fi settings.
2. Find "PowerOcean\_xxxx" and click it to enter the password for the Wifi, then click "Join".
3. After successfully connected your phone to "PowerOcean\_ xxxx", tap the "EcoFlow Pro" on the top left of your phone's Wi-Fi setting page to shift back and proceed to commissioning.

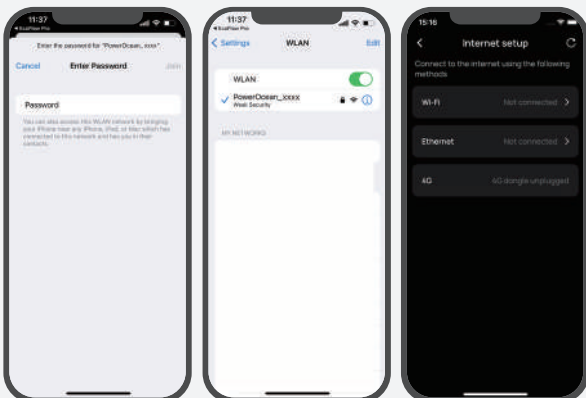
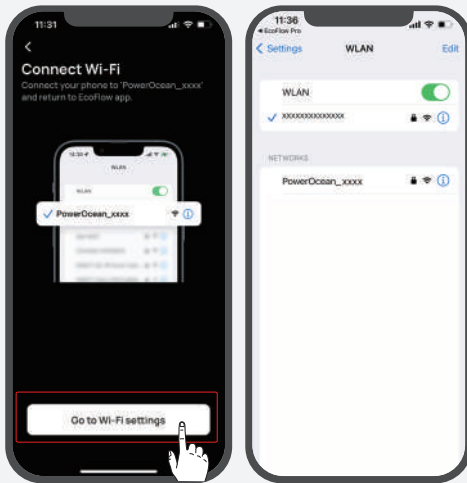
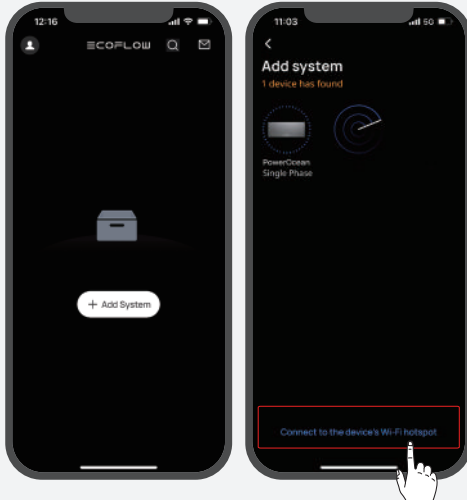

## 5

### COMMISSIONING

After bound device successfully, the device enters the four-step commissioning process.

#### Step1: Internet Setup

click **Internet Setup** to start the network configuration.

#### Method 1: Wi-Fi

Click **WiFi**, select the appropriate WiFi name and enter the password and click **continue**.

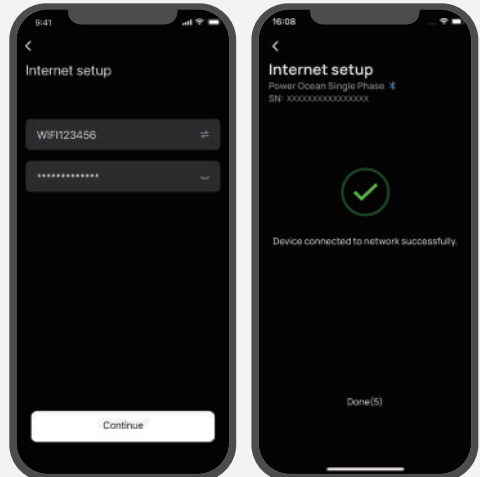
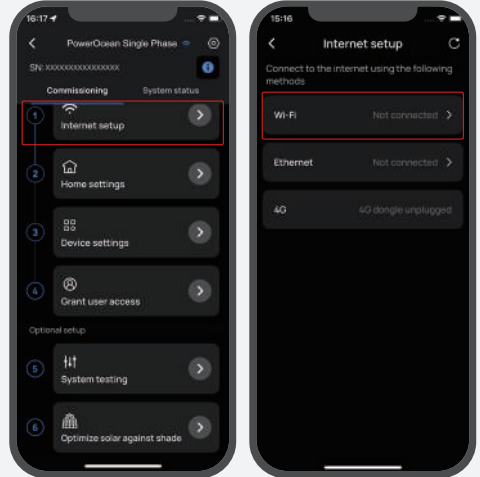

#### Method 2: Ethernet

Connect the system to a router using a network cable, wait a minute before proceeding. Then click "Ethernet" to set DHCP/Static mode. (Both modes are available)



- By default, the IP setting is DHCP mode, which assigns dynamic IP address to the device (recommended).
- Static mode requires manual configuration of the IP address. Please make sure the IP address is not in conflict with other devices, you can visit the router to check the IP addresses of other devices.



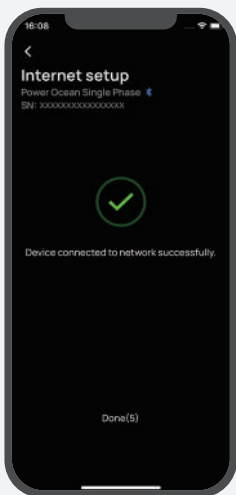
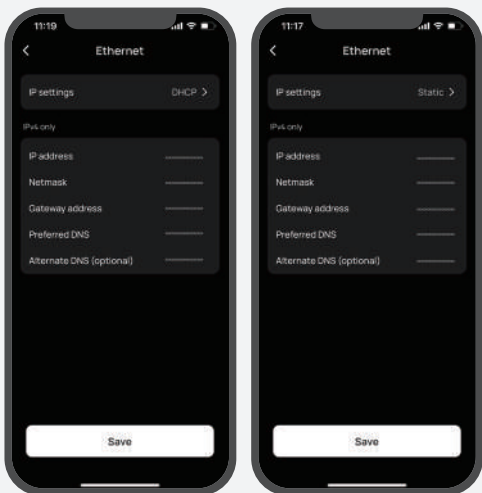
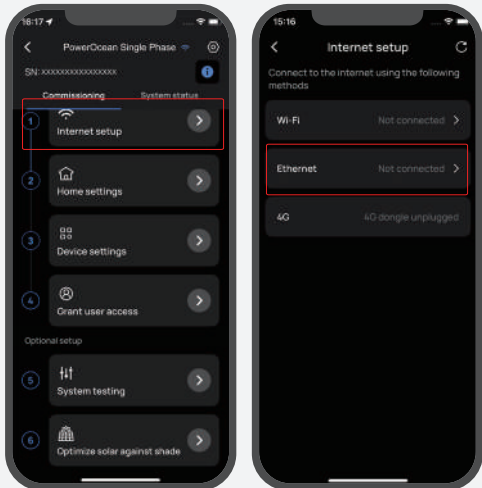

### Method 3: 4G

1. Install a nano SIM card to the EcoFlow 4G Dongle ESS(EU).
2. Install the dongle onto the USB port (4G) of the inverter.
3. Activate your SIM card through App.



For more details about EcoFlow 4G Dongle ESS(EU), please refer to its user manual.

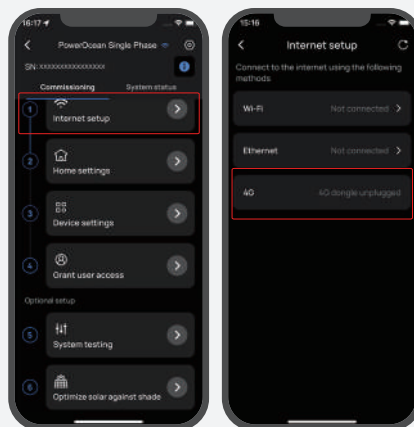

### Step2: Home Setting

Click **Home Setting** to enter the corresponding house address.  
(Optional) Set the electricity rate.

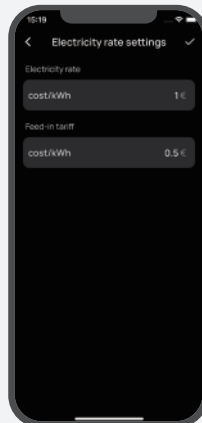
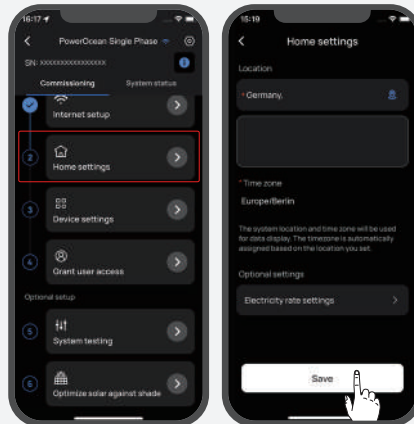

### Step3: Device Setting

a. Click **Device Setting** to verify that the devices in the device list match the connected devices.

#### (Optional) Update firmware before carrying out Device Setting.

If there is a firmware update available for the EcoFlow PowerOcean system, the update page will pop up to notify you when proceeding this step. The "Skip" button is available for some update that is not urgent. It is highly recommended that you upgrade your PowerOcean firmware for seamless experience immediately.

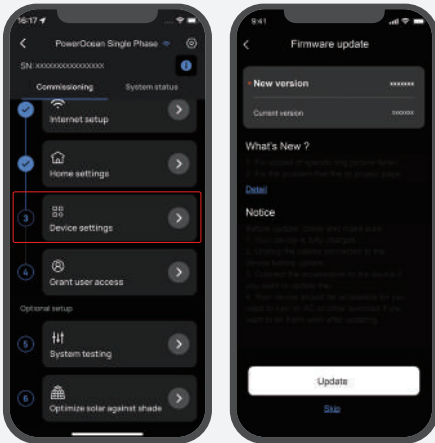

#### System check before carrying out Device Setting.

During the initial commissioning, there is a system check available for the EcoFlow PowerOcean system, allowing you to confirm all the system connections are correct.

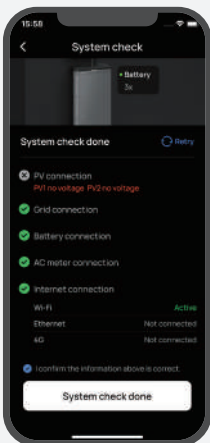

b. Set grid code, system work mode and feed-in power limitation.

c. (Optional) You can also tap **Customize Settings** to set Connection parameters, Voltage Protection parameters, Frequency Protection parameters, Reactive Power parameters and other parameters. (Please follow local regulations, if you need to change any of these parameters, please contact your local power organization first.)

d. Click **Done** to finish the commissioning.

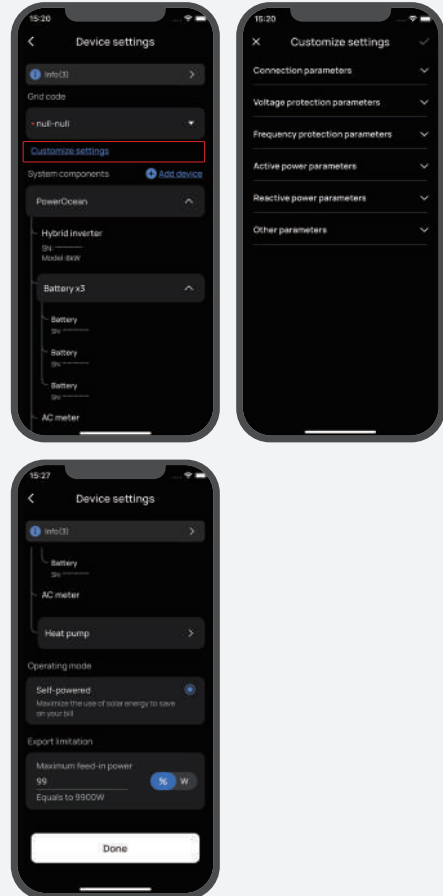

## 6

### GRANT USER ACCESS

Click **Grant User Access** for a home owner access QR code to allow users to scan it.



- After manually adding device **EcoFlow PowerOcean** using the EcoFlow User App, users scan the home owner access QR code to bind it.

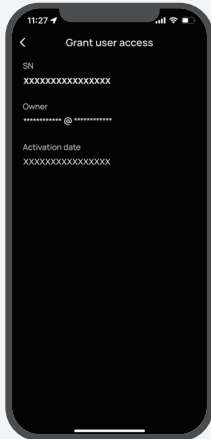
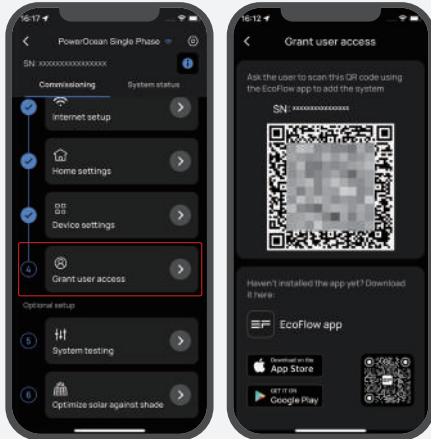

## 7

### (OPTIONAL) SYSTEM TESTING

To test the go off-grid feature, you can toggle the button to switch the connection status of the system.

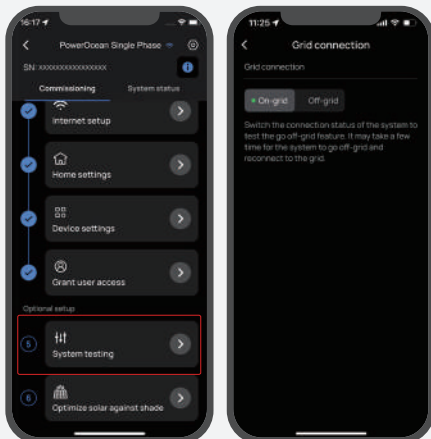

## 8

### (OPTIONAL) OPTIMIZE SOLAR AGAINST SHADE

If this feature is enabled, the system will optimize solar generation in shaded conditions at your setup intervals to track the maximum power point. Solar generation may fluctuate.

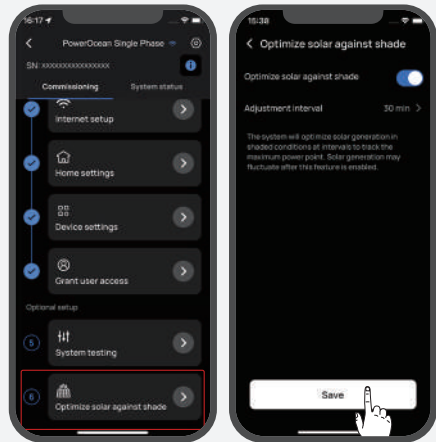

### (OPTIONAL) ADD DEVICE TO THE SYSTEM

(Optional) Tap "Add Device" to integrate devices into this system, such as SG READY certified Heat Pump or charging pile etc., and setup relevant parameters.

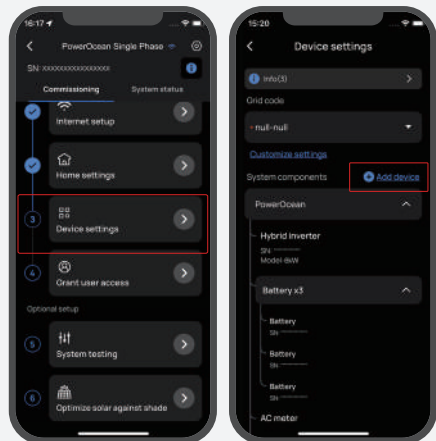

# How Users Add Devices

## 1. DOWN AND INSTALL ECOFLOW USER APP (FOR USER ONLY)

Scan the QR code or download at:  
<https://download.ecoflow.com/app>



## 2. CREATE NEW ACCOUNT AND LOG IN.

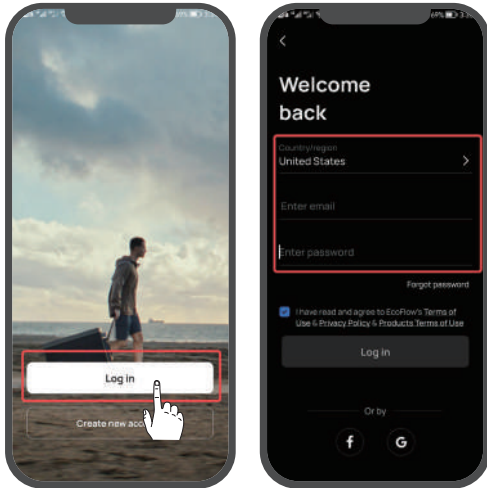

## 3. ADD DEVICE MANUALLY.

